

# IS31AP4912

## STEREO HEADPHONE DRIVER

August 2018

### GENERAL DESCRIPTION

The IS31AP4912 is a Class-AB stereo headphone inverting amplifier with charge pump controller capable of delivering 30mW into a 32Ω load with less than 0.1% THD+N. The integrated charge pump generates a negative reference voltage to bias the outputs about ground. This eliminates the need for output DC-blocking capacitors resulting in a lower component count and cost. The gain of the amplifier is adjusted via external resistors.

The IS31AP4912 integrates click-and-pop suppression circuitry to eliminate speaker noise which would occur during power ON/OFF transitions. It also integrates a thermal protection circuit to shutdown the amplifier if it gets too hot. Setting the SDB pin to a low state will cause the IS31AP4912 to enter a low-power shutdown mode with a quiescent current of less than 1μA.

The IS31AP4912 is ideal for small portable electronics where size, battery life and cost are critical design parameters. IS31AP4912 is available in a space saving UTQFN-12 (2mm × 2mm) package. It operates from 2.7V to 5.5V over the temperature range of -40°C to +85°C.

### FEATURES

- Supply voltage from 2.7V ~ 5.5V
- Ultra-low current shutdown mode
- Ground referenced outputs
- - No output DC-blocking capacitors
- Low output noise (7μV)
- High SNR (103dB)
- -95dB PSRR
- Thermal protect circuit
- Integrated click-and-pop suppression circuitry
- UTQFN-12 (2mm × 2mm) package

### APPLICATIONS

- Cellular handsets and PDAs
- Notebook PC
- MP3
- Portable gaming

### TYPICAL APPLICATION CIRCUIT

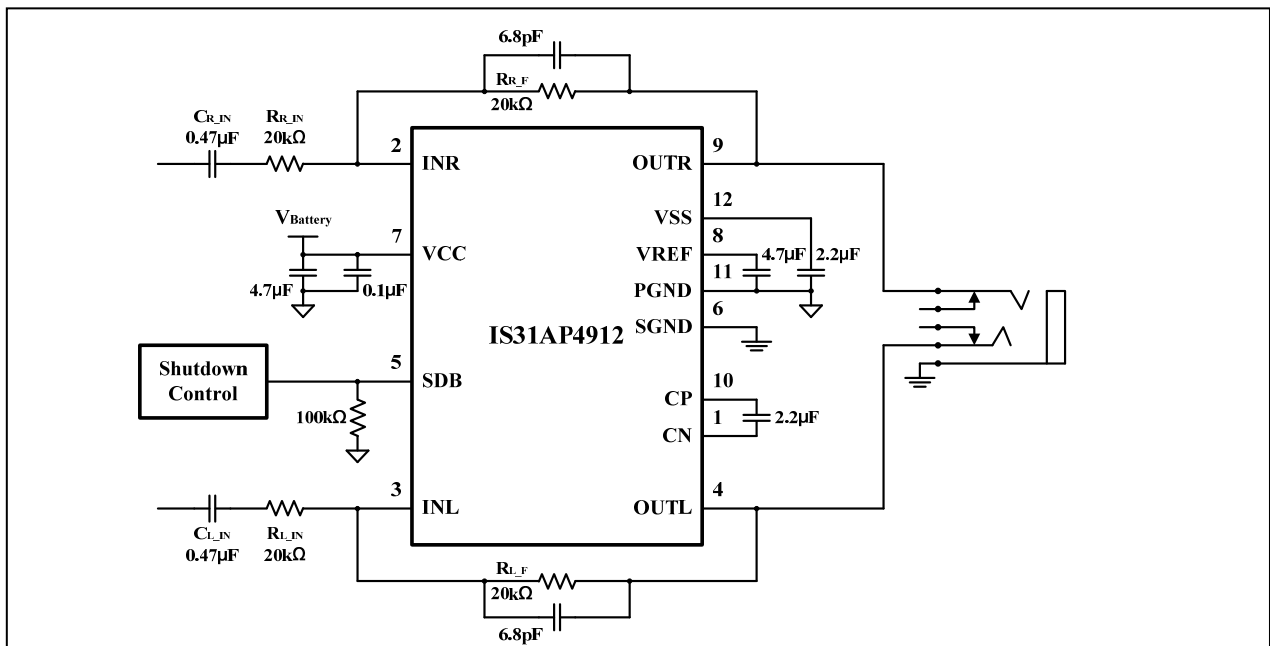
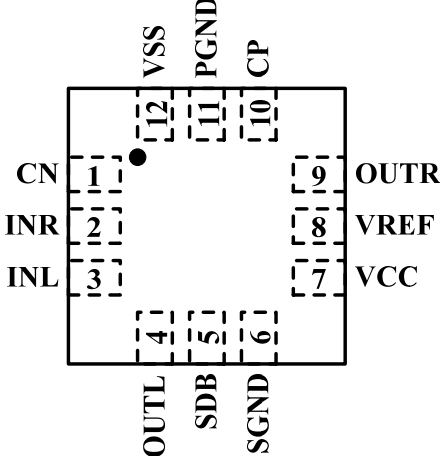

Figure 1 Typical Application Circuit

**Note 1:** The SGND and PGND pins of the IS31AP4912 must be routed separately back to the decoupling capacitor in order to provide optimum device operation. If the SGND and PGND pins are connected directly to each other, the device will function, but the noise and THD performance do not meet the specifications.

# IS31AP4912

## PIN CONFIGURATION

Package	Pin Configuration (Top View)
UTQFN-12	

## PIN DESCRIPTION

No.	Pin	Description
1	CN	Charge pump flying capacitor negative terminal.
2	INR	Right channel audio input.
3	INL	Left channel audio input.
4	OUTL	Left channel audio output.
5	SDB	Shutdown control terminal, active low.
6	SGND	Signal Ground.
7	VCC	Supply voltage.
8	VREF	Internal produced supply voltage for charge pump and audio power amplifier.
9	OUTR	Right channel audio output.
10	CP	Charge pump flying capacitor positive terminal.
11	PGND	Power ground.
12	VSS	Output from charge pump.



# IS31AP4912

## ORDERING INFORMATION

Industrial Range: -40°C to +85°C

Order Part No.	Package	QTY/Reel
IS31AP4912-UTLS2-TR	UTQFN-12, Lead-free	3000

Copyright © 2018 Integrated Silicon Solution, Inc. All rights reserved. ISSI reserves the right to make changes to this specification and its products at any time without notice. ISSI assumes no liability arising out of the application or use of any information, products or services described herein. Customers are advised to obtain the latest version of this device specification before relying on any published information and before placing orders for products. Integrated Silicon Solution, Inc. does not recommend the use of any of its products in life support applications where the failure or malfunction of the product can reasonably be expected to cause failure of the life support system or to significantly affect its safety or effectiveness. Products are not authorized for use in such applications unless Integrated Silicon Solution, Inc. receives written assurance to its satisfaction, that:

- a.) the risk of injury or damage has been minimized;
- b.) the user assume all such risks; and
- c.) potential liability of Integrated Silicon Solution, Inc is adequately protected under the circumstances

# IS31AP4912

## ABSOLUTE MAXIMUM RATINGS

Supply voltage, $V_{CC}$	-0.3V ~ +6.0V
Voltage at any input pin	-0.3V ~ $V_{CC}+0.3V$
Maximum junction temperature, $T_{JMAX}$	150°C
Storage temperature range, $T_{STG}$	-65°C ~ +150°C
Operating temperature range, $T_A = T_J$	-40°C ~ +85°C
Package thermal resistance, junction to ambient (4 layer standard test PCB based on JESD 51-2A), $\theta_{JA}$	126.1°C/W
ESD (HBM)	±8kV
ESD (CDM)	±1kV

**Note 2:** Stresses beyond those listed under "Absolute Maximum Ratings" may cause permanent damage to the device. These are stress ratings only and functional operation of the device at these or any other condition beyond those indicated in the operational sections of the specifications is not implied. Exposure to absolute maximum rating conditions for extended periods may affect device reliability.

## ELECTRICAL CHARACTERISTICS

$V_{CC} = 2.7V \sim 5.5V$ ,  $T_A = 25^\circ C$ , unless otherwise noted. Typical value is  $T_A = 25^\circ C$ ,  $V_{CC} = 3.6V$ .

Symbol	Parameter	Condition	Min.	Typ.	Max.	Unit
$V_{CC}$	Supply voltage		2.7		5.5	V
$I_{CC}$	Quiescent current	No load		3	5.5	mA
$I_{SD}$	Shutdown current	$V_{SDB} = 0V$			1	μA
$f_{OSC}$	Charge pump operating frequency			250		kHz
$ V_{OS} $	Output offset voltage	$V_{IN} = 0V$		1		mV
$V_{IH}$	High-level input voltage		1.4			V
$V_{IL}$	Low-level input voltage				0.4	V
$T_{SD}$	Thermal shutdown			160		°C
$T_{SD\_HYS}$	Thermal shutdown hysteresis			45		°C

## ELECTRICAL CHARACTERISTICS (NOTE 3)

$T_A = 25^\circ C$ ,  $V_{CC} = 3.6V$ , unless otherwise noted.

Symbol	Parameter	Condition	Min.	Typ.	Max.	Unit
$P_O$	Output power	THD+N = 1%, $R_L = 32\Omega$ , $f = 1kHz$		30		mW
THD+N	Total harmonic distortion plus noise	$P_O = 20mW$ , $R_L = 32\Omega$ , $f = 1kHz$		0.024		%
$t_{WU}$	Wake-up time from shutdown			39		ms
PSRR	Power supply rejection ratio	$V_{P-P} = 200mV$ , $R_L = 32\Omega$ , $f = 217Hz$		-95		dB
		$V_{P-P} = 200mV$ , $R_L = 32\Omega$ , $f = 1kHz$		-93		dB
$V_{NO}$	Output voltage noise			7		μV
SNR	Signal-to-noise ratio	$P_O = 30mW$ , THD+N = 0.1%		103		dB

**Note 3:** Guaranteed by design.

# IS31AP4912

## TYPICAL PERFORMANCE CHARACTERISTIC

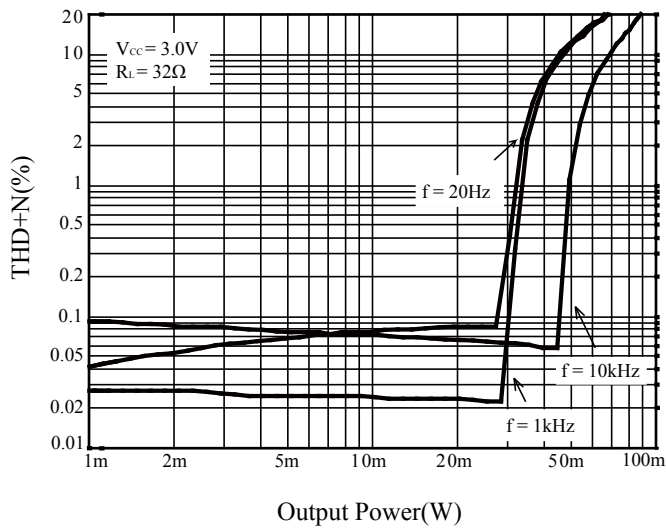

Figure 2 THD+N vs. Output Power

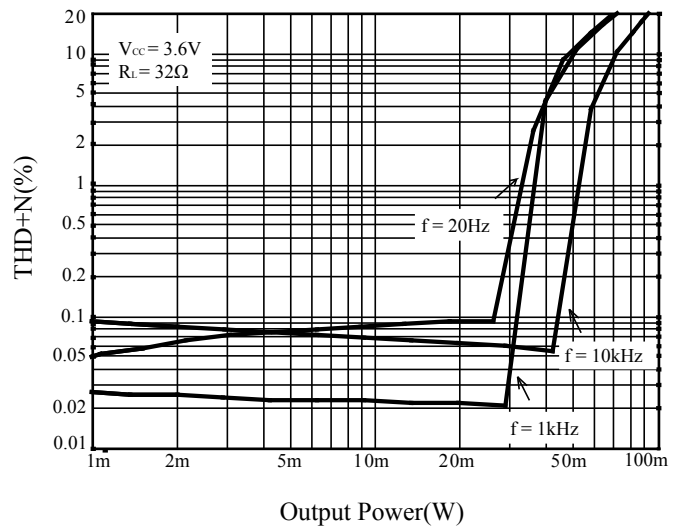

Figure 3 THD+N vs. Output Power

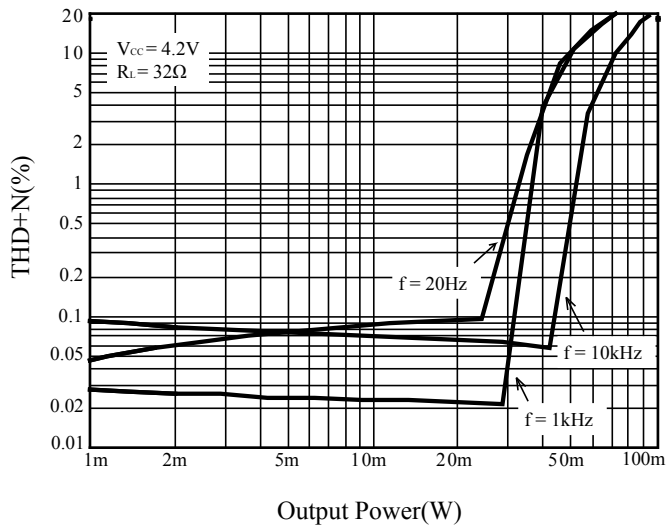

Figure 4 THD+N vs. Output Power

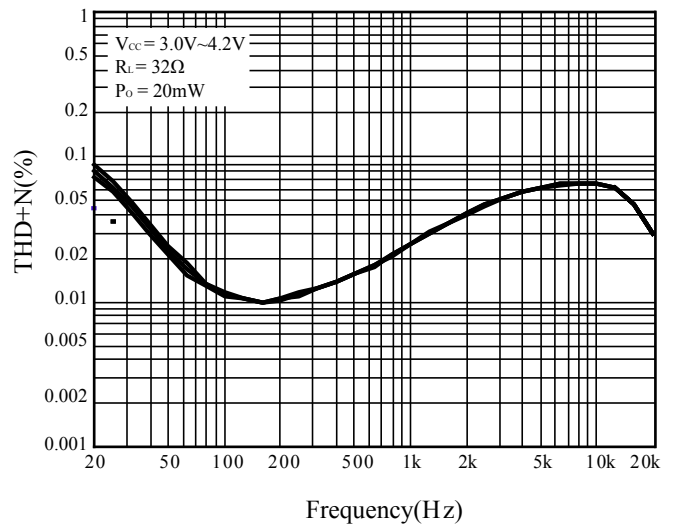

Figure 5 THD+N vs. Frequency

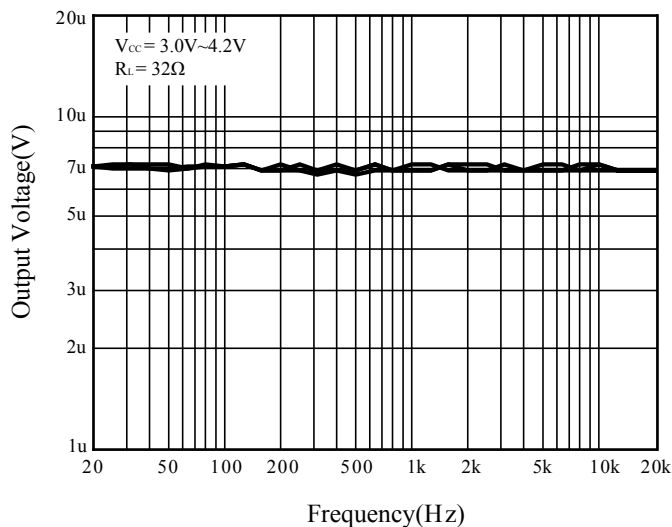

Figure 6 Noise

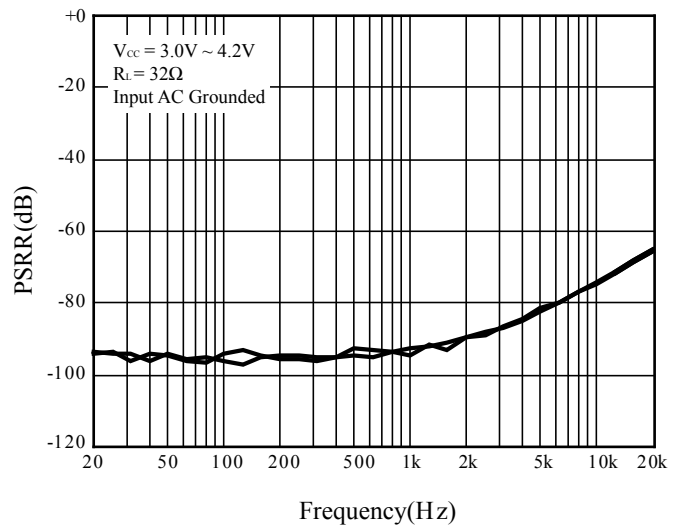
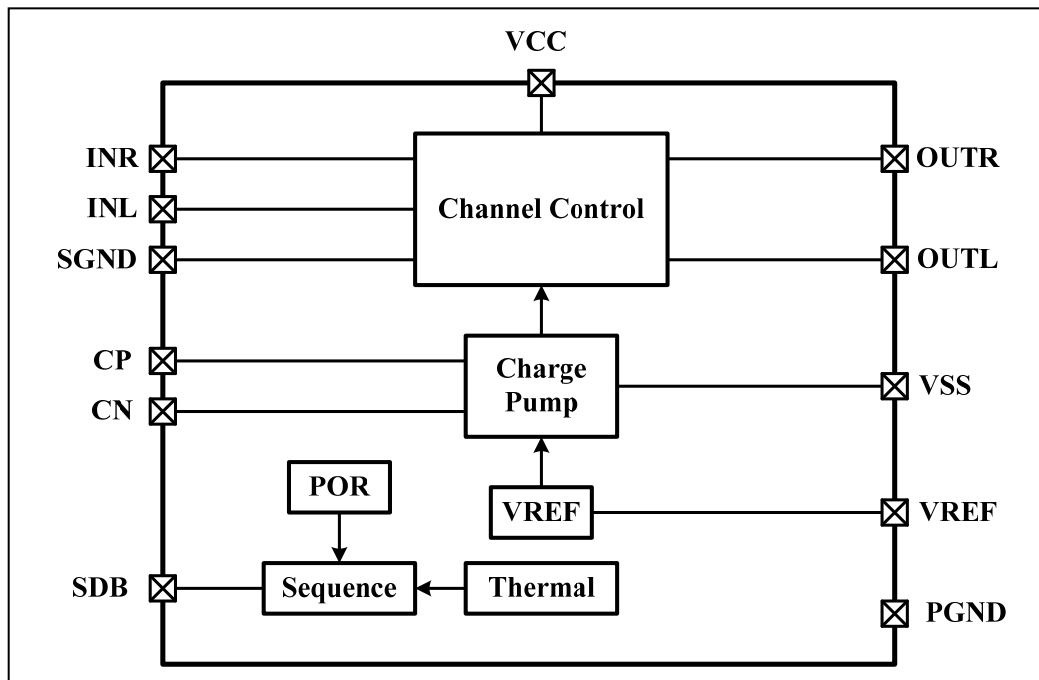

Figure 7 PSRR vs. Frequency

# IS31AP4912

## FUNCTIONAL BLOCK DIAGRAM



# IS31AP4912

## APPLICATION INFORMATION

### CHARGE PUMP CONVERTER

The IS31AP4912 integrates an inverting charge pump to change the input supply voltage ( $V_{CC}$ ) into a negative voltage resulting in a 0V (Gnd) reference voltage output. This eliminates the need for output coupling capacitors, improves low frequency response and doubles dynamic range.

The charge pump converter only requires three small ceramic capacitors: supply decoupling capacitor, output bypass capacitor and a flying capacitor.

Choose low ESR capacitors to ensure the best operating performance and place the capacitors as close as possible to the IS31AP4912.

### GAIN SETTING

The input resistors ( $R_{IN}$ ) and feedback resistors ( $R_F$ ) set the gain of the amplifier according to Equation (1).

$$Gain(A_V) = \frac{V_{OUT}}{V_{IN}} = -\frac{R_F}{R_{IN}} \left( \frac{V}{V} \right) \quad (1)$$

For example, in Figure 1:

$R_F = 20k\Omega$ ,  $R_{IN} = 20k\Omega$ ,

$$\text{so, } Gain = -\frac{20}{20} = -1 \left( \frac{V}{V} \right)$$

The negative sign in the equation indicates an inversion of the output signal with respect to the input as it is 180 degrees out of phase. This is due to the feedback being a negative value. The Equation (2) for the output voltage  $V_{OUT}$  also shows that the circuit is linear for a fixed gain as:

$$V_{OUT} = Gain \times V_{IN} = -\left(\frac{R_F}{R_{IN}}\right) \times V_{IN} \quad (2)$$

Resistor matching is very important since the balanced output on the reference voltage depends on matched resistor ratios. CMRR, PSRR, and cancellation of the second harmonic distortion diminish if resistor mismatch occurs. Therefore, it is recommended to use 1% tolerance resistors or better to keep the performance optimized. Matching is more critical than overall tolerance. Resistor arrays with 1% matching can be used with a tolerance greater than 1%.

Place the input resistors very close to the IS31AP4912 to limit noise injection on the high-impedance nodes.

### INPUT CAPACITOR ( $C_{IN}$ )

The input capacitors and input resistors produce a -3dB high pass filter cutoff frequency with the corner frequency,  $f_c$ , determined in Equation (3).

$$f_c = \frac{1}{2\pi R_{IN} C_{IN}} \quad (3)$$

For example, in Figure 1:

$R_{IN} = 20k\Omega$ ,  $C_{IN} = 0.47\mu F$ ,

$$\text{so, } f_c = \frac{1}{2\pi \times 20k\Omega \times 0.47\mu F} \approx 17 Hz$$

The value of the input capacitors ( $CR_{in}$  and  $CL_{in}$  in Figure 1) is important to consider as they directly affect the bass (low frequency) performance of the circuit. The capacitors should have a tolerance of  $\pm 10\%$  or better, because any mismatch in capacitance causes an impedance mismatch at the corner frequency and below.

### DESIGN NOTE

#### COMPONENT SELECTION

The value and ESR (equivalent series resistance) of the output and flying capacitor for the charge pump will affect output ripple and transient performance. Low ESR capacitors will lower the charge pump output impedance resulting in higher output power due to a lower negative supply headroom. Use low ESR X7R or X5R ceramic capacitors with 2.2 $\mu F$  values for best performance.

All the capacitors should support at least 10V.

#### PCB LAYOUT

The decoupling capacitors should be placed close to the VCC pin and the output capacitors should be placed close to the VSS pin. The flying capacitor should be placed close to the CN and CP pins. The input capacitors and input resistors should be placed close to the INR and INL pins and the traces must be parallel to prevent noise. The traces of OUTR and OUTL pins connected to the headphone should be as possible as short and wide. The recommended width is 0.5mm.

Trace width should be at least 0.75mm for the power supply and the ground plane. The SGND and PGND pins of the IS31AP4912 must be routed separately back to the decoupling capacitor in order to provide proper device operation. If the SGND and PGND pins are connected directly to each other, the part functions without risk of failure, but the noise and THD performance do not meet the specifications.

# IS31AP4912

## CLASSIFICATION REFLOW PROFILES

Profile Feature	Pb-Free Assembly
<b>Preheat &amp; Soak</b> Temperature min (T <sub>smin</sub> ) Temperature max (T <sub>smax</sub> ) Time (T <sub>smin</sub> to T <sub>smax</sub> ) (t <sub>s</sub> )	150°C 200°C 60-120 seconds
Average ramp-up rate (T <sub>smax</sub> to T <sub>p</sub> )	3°C/second max.
Liquidous temperature (T <sub>L</sub> ) Time at liquidous (t <sub>L</sub> )	217°C 60-150 seconds
Peak package body temperature (T <sub>p</sub> )*	Max 260°C
Time (t <sub>p</sub> )** within 5°C of the specified classification temperature (T <sub>c</sub> )	Max 30 seconds
Average ramp-down rate (T <sub>p</sub> to T <sub>smax</sub> )	6°C/second max.
Time 25°C to peak temperature	8 minutes max.

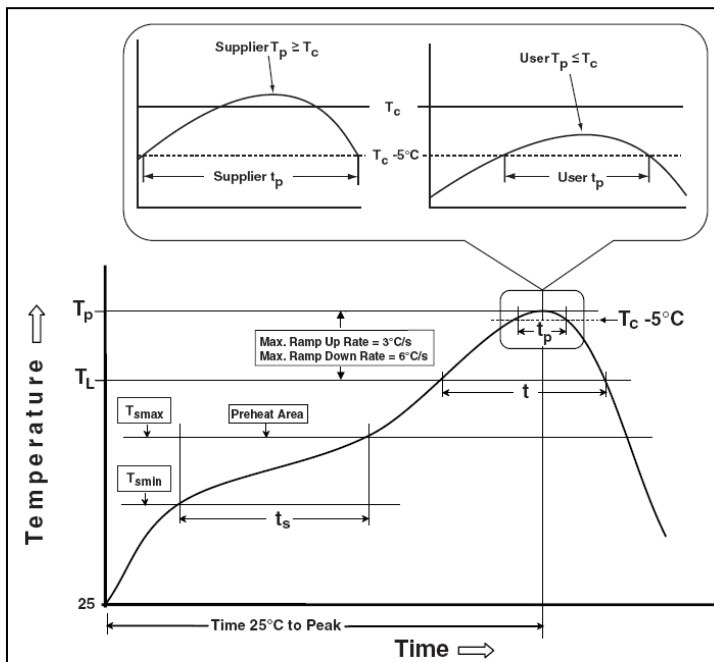

Figure 8 Classification Profile



# IS31AP4912

## PACKAGING INFORMATION

### UTQFN-12

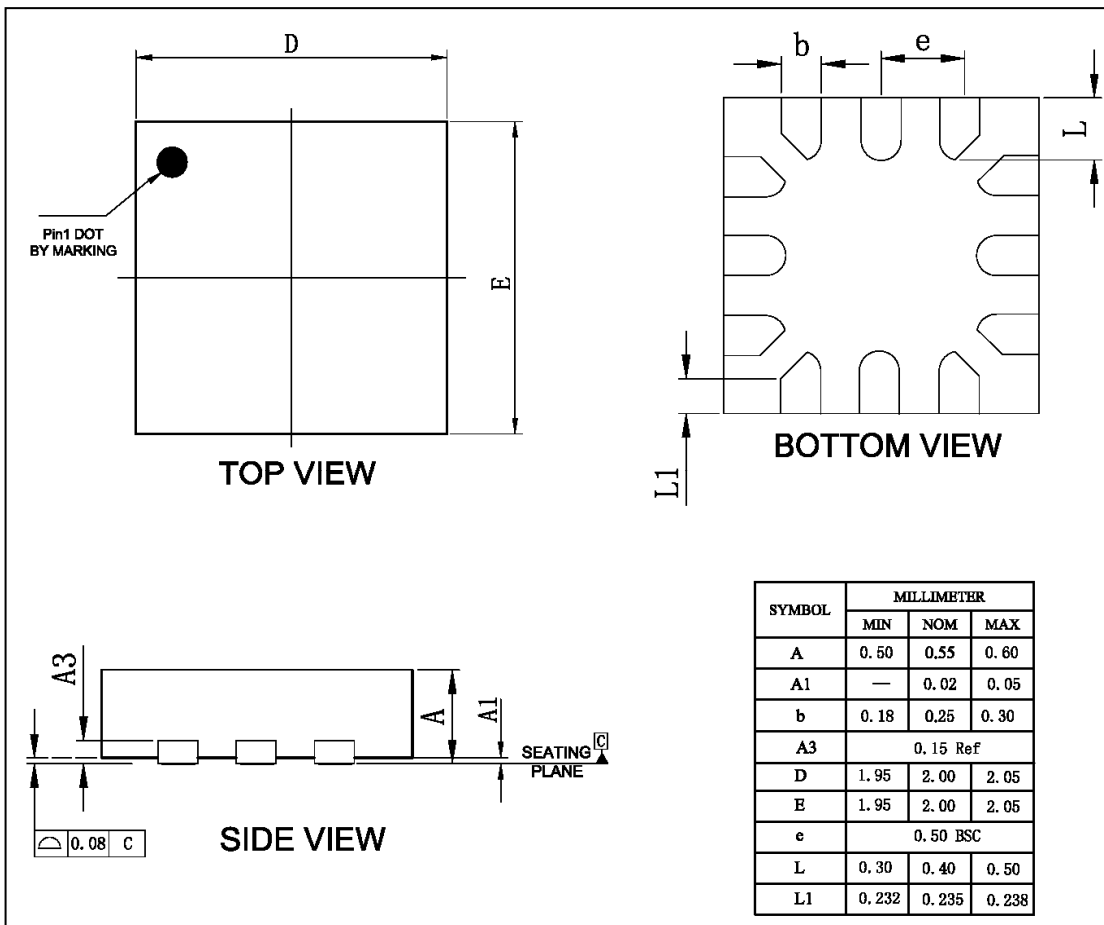

# IS31AP4912

## RECOMMENDED LAND PATTERN

### UTQFN-12

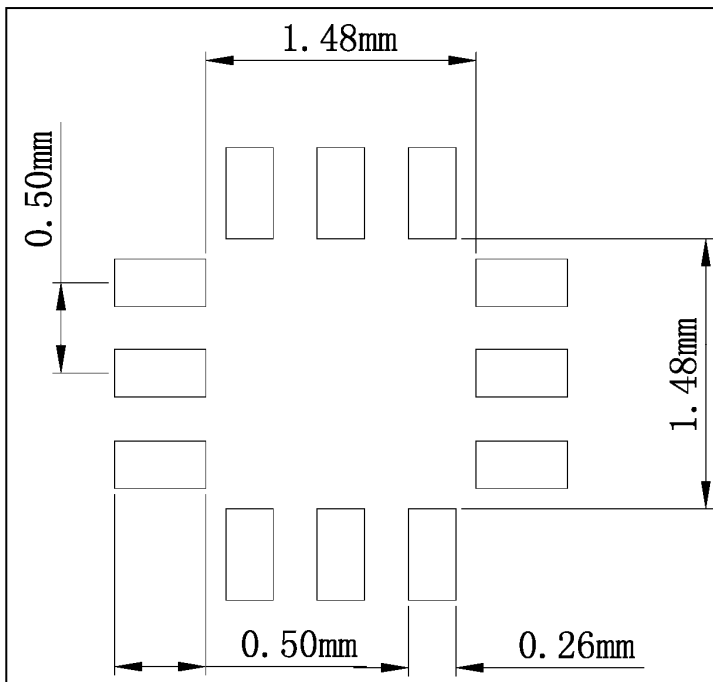

**Note:**

1. Land pattern complies to IPC-7351.
2. All dimensions in MM.
3. This document (including dimensions, notes & specs) is a recommendation based on typical circuit board manufacturing parameters. Since land pattern design depends on many factors unknown (eg. user's board manufacturing specs), user must determine suitability for use.

# IS31AP4912

## REVISION HISTORY

Revision	Detail Information	Date
A	Initial release	2011.11.17
B	Update POD	2013.06.06
C	1. Add ESD value and $\theta_{JA}$ 2. Add land pattern and update POD	2015.12.23
D	Update Equation (1) and clarify operating description.	2018.08.14